

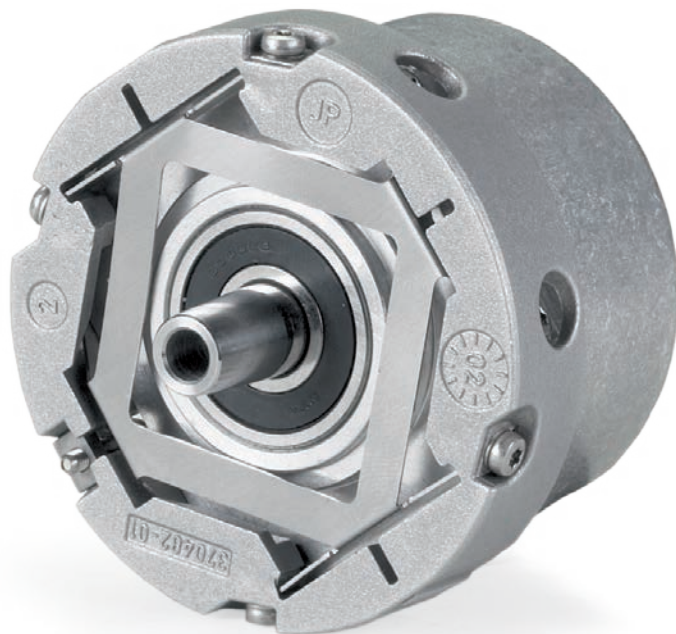

HEIDENHAIN



Product Information

ECN 1313 **EQN 1325**

Absolute Rotary Encoders
with Tapered Shaft and 01r1
or 07r1 SSI interface

ID 1353127-xx

ID 1353128-xx

ID 1353130-xx

ECN/EQN 1300 series

Absolute rotary encoders

- 06 stator coupling for axial mounting
- 65B tapered shaft

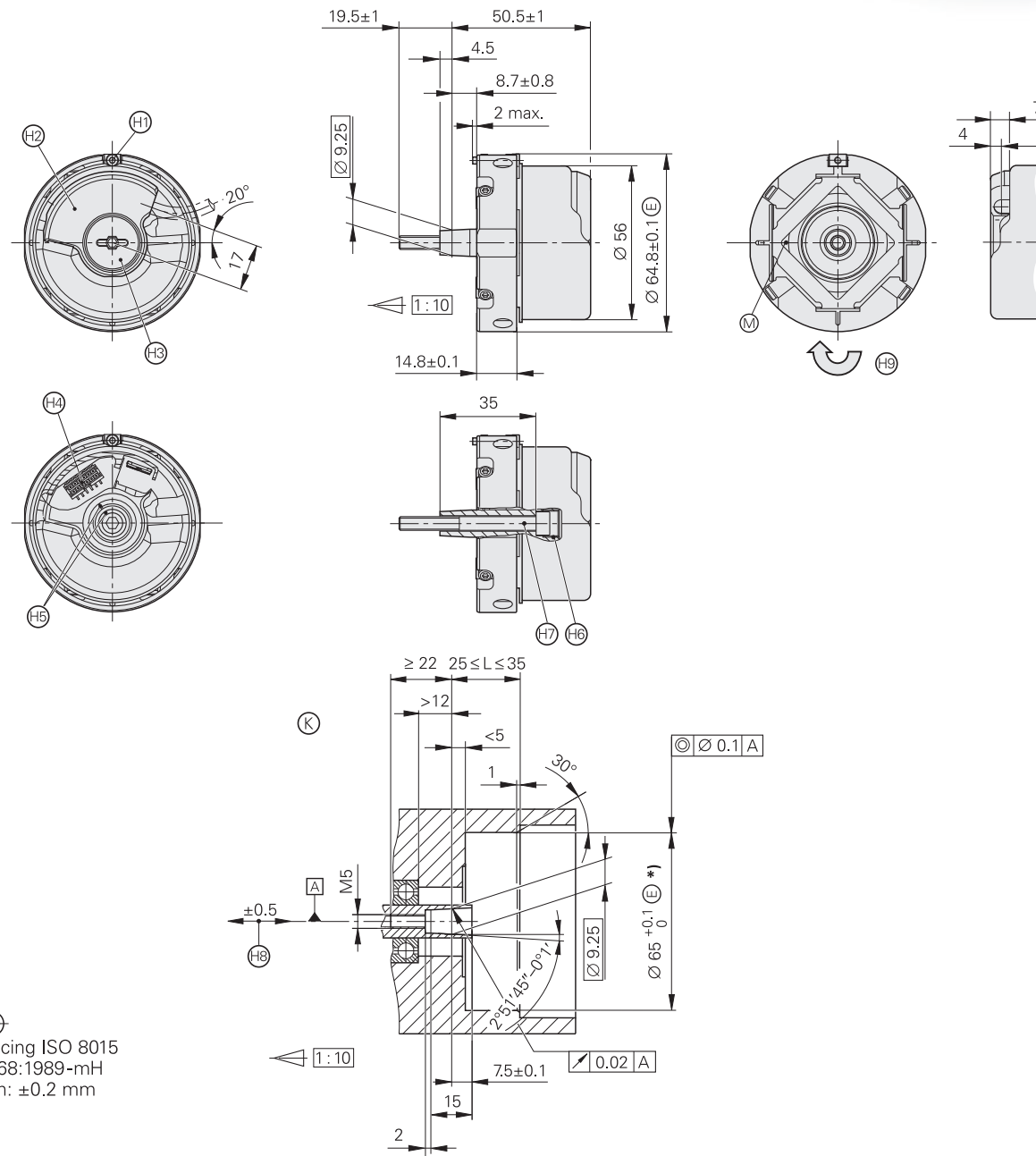

mm
 Tolerancing ISO 8015
 ISO 2768:1989-mH
 ≤ 6 mm: ± 0.2 mm

- ▣ = Bearing of mating shaft
- ⊙ = Required mating dimensions
- ⊙ = Measuring point for operating temperature
- 1 = Clamping screw for coupling ring: width A/F 2; tightening torque: 1.25 Nm -0.2 Nm
- 2 = Die-cast cover
- 3 = Screw plug: widths A/F 3 and 4; tightening torque: 5 Nm $+0.5$ Nm
- 4 = ECN/EQN: 16-pin PCB connector (12+4)
- 5 = ECN/EQN: zero position of shaft and housing
- 6 = M10 back-off thread
- 7 = Self-locking screw: DIN 6912 M5x50; width A/F 4; tightening torque: 5 Nm $+0.5$ Nm
- 8 = Compensation of mounting tolerances and thermal expansion; no dynamic movement permitted
- 9 = Direction of shaft rotation for ascending position values

	Absolute	
	ECN 1313	EQN 1325
Interface	SSI	
Ordering designation	SSI01r1	SSI07r1
Position values per rev.	8192 (13 bits)	
Revolutions	-	4096 (12 bits)
Electrically permissible speed/error ²⁾	15000 rpm/ ± 12 LSB	
Calculation time t_{cal}	$\leq 5 \mu s$	
Incremental signals	$\sim 1 V_{PP}$ ¹⁾	
Line count*	512	2048
Cutoff frequency -3 dB	≥ 500 kHz	
System accuracy	512 lines: $\pm 60''$; 2048 lines: $\pm 20''$	
Electrical connection	16-pin (12+4) PCB connector	
Supply voltage	4.75 V to 30 V DC	
Power consumption (maximum)	4.75 V: ≤ 600 mW 30 V: ≤ 775 mW	4.75 V: ≤ 675 mW 30 V: ≤ 875 mW
Current consumption (typical)	5 V: 70 mA (without load)	5 V: 85 mA (without load)
Shaft	Tapered shaft \varnothing (9.25 mm); taper: 1:10	
Mech. permiss. shaft speed n	≤ 15000 rpm	≤ 12000 rpm
Starting torque (typical)	0.01 Nm (at 20 °C)	
Moment of inertia of rotor	$2.6 \cdot 10^{-6}$ kgm ²	
Natural frequency f_N (typical)	1800 Hz	
Permissible axial motion of measured shaft	± 0.5 mm	
Vibration 55 Hz to 2000 Hz	≤ 300 m/s ² ³⁾ (EN 60068-2-6)	
Shock 6 ms	≤ 2000 m/s ² (EN 60068-2-27)	
Operating temperature	-40 °C to 115 °C	
Protection EN 60529	IP40 when mounted	
Mass	≈ 0.25 kg	
ID number	1353127-xx ⁴⁾ 1353128-xx	1353130-xx

* Please select when ordering

- 1) More rigorous tolerances
 - Signal amplitude: 0.8 V_{PP} to 1.2 V_{PP}
 - Asymmetry: 0.05
 - Signal ratio: 0.9 to 1.1
 - Phase angle: 90° $\pm 5^\circ$ el.

2) Speed-dependent deviations between absolute and incremental signals

3) Valid as per standard at room temperature; at operating temperatures of up to 100 °C: ≤ 300 m/s²; up to 115 °C: ≤ 150 m/s²

4) Encoder with hybrid bearing

Mounting

The tapered shaft of the rotary encoder is pressed onto the measured shaft and fastened with a central screw. The stator coupling is clamped by means of an axially tightenable screw in a location hole.

Mounting accessories

Mounting aid

To avoid damage to the cable, use the mounting aid to connect and disconnect the cable assembly. The pulling force must be applied solely to the connector and not to the wires.

ID 1075573-01

For more mounting information and mounting aids, see the **Mounting Instructions** and the **Encoders for Servo Drives** brochure. The mounting quality can be inspected with the **PWM 21** and **ATS** software.

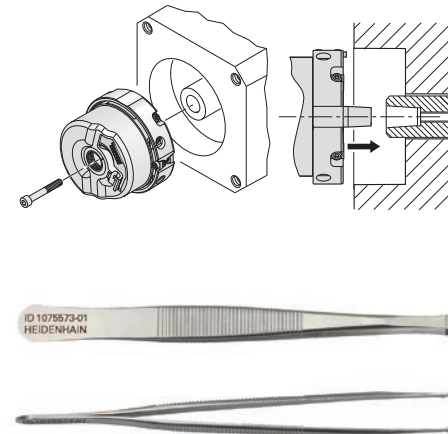

Interface

SSI position values

The **position value** is transmitted, starting with the most significant bit (MSB), over the data lines (DATA) in synchronism with a clock signal (CLOCK) provided by the control. The SSI standard data word length for singleturn encoders is 13 bits, and for multiturn encoders, 25 bits. In addition to the absolute position values, **incremental signals** can be transmitted as well. For a description of the signals, see $1 V_{PP}$ *incremental signals* in the *Rotary Encoders* brochure.

The following **functions** cannot be activated via programming inputs:

- **Direction of rotation**
- **Zero reset** (setting to zero)

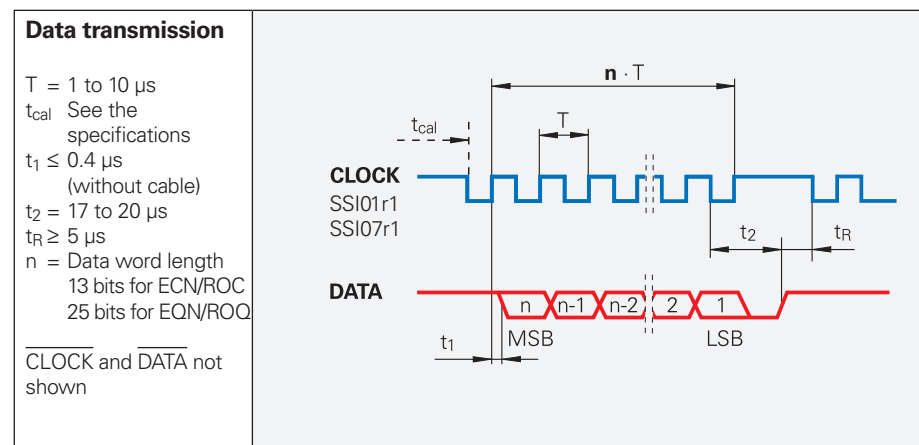

Electrical connection

Output cables for ECN 1313 with SSI01r1 / EQN 1325 with SSI07r1

EPG output cables inside the motor housing $\varnothing 4.5 \text{ mm}$ (with shield crimp $\varnothing 6.1 \text{ mm}$); $16 \times 0.057 \text{ mm}^2$ and TPE wires $2 \times 0.25 \text{ mm}^2$ for temperature sensor		
With 12-pin PCB connector and 17-pin M23 angle flange socket (male)		ID 332201-xx
With 12-pin PCB connector and unstripped cable end		ID 332202-xx

Pin layout SSI01r1 / SSI07r1

17-pin M23 coupling or flange socket						16-pin (12+ 4) PCB connector													
	Power supply					Incremental signals				Serial data transmission									
							7	1	10	4	11	15	16	12	13	14	17	8	9
							1b	6a	4b	3a	/	2a	5b	4a	3b	6b	1a	2b	5a
	U_p	Sensor U_p	0V	Sensor 0V	Internal shield		A+	A-	B+	B-	DATA	\overline{DATA}	CLOCK	\overline{CLOCK}					
	Brown/Green	Blue	White/Green	White	/		Green/Black	Yellow/Black	Blue/Black	Red/Black	Gray	Pink	Violet	Yellow					

Other signals			
		5	6
		/	/
		T^+ ¹⁾	T^- ¹⁾
		Brown ¹⁾	White ¹⁾

Cable shield connected to housing; U_p = Power supply voltage; T = Temperature
Sensor: The sense line is connected in the encoder with the corresponding power line.
 Vacant pins or wires must not be used!
¹⁾ Connections for an external temperature sensor (only for output cables inside the motor, see *Temperature measurement in motors*); if used, please refer to the information about electromagnetic compatibility in the *General electrical information* section of the *Interfaces of HEIDENHAIN Encoders* brochure.

HEIDENHAIN

DR. JOHANNES HEIDENHAIN GmbH
 Dr.-Johannes-Heidenhain-Str. 5
 83301 Traunreut, Germany
 ☎ +49 8669 31-0
 📠 +49 8669 32-5061
 info@heidenhain.de
 www.heidenhain.com

This Product Information document supersedes all previous editions, which thereby become invalid. The basis for ordering from HEIDENHAIN is always the Product Information document edition valid when the order is placed.

More information:

Comply with the requirements described in the following documents to ensure correct and intended operation:	
• Brochure: <i>Encoders for Servo Drives</i>	208922-xx
• Brochure: <i>Cables and Connectors</i>	1206103-xx
• Brochure: <i>Interfaces of HEIDENHAIN Encoders</i>	1078628-xx
• SSI Interface Description	391244-xx
• Mounting Instructions: <i>ECN 1313, EQN 1325, ECN 1325, EQN 1337</i>	1139530-xx